

Straight Joiner Installation Instruction

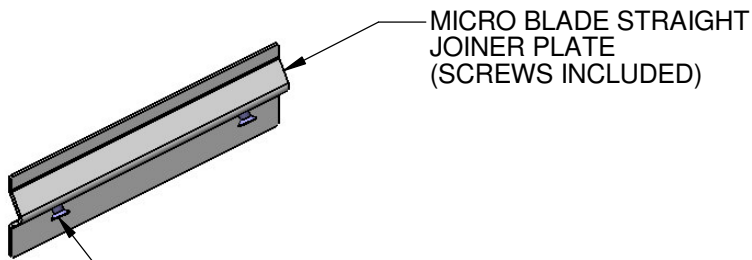

WITH EXTRUSIONS JOINED AND HELD TOGETHER FIRMLY, TIGHTEN LEFT HAND SCREW FIRST. THE TURNING/TIGHTENING OF THE SECOND SCREW WILL DRAW THE EXTRUSIONS TOGETHER MORE.

DO NOT OVERTIGHTEN THE SCREWS OR ELSE THE OUTSIDE SURFACE OF THE EXTRUSION WILL BE DEFORMED.

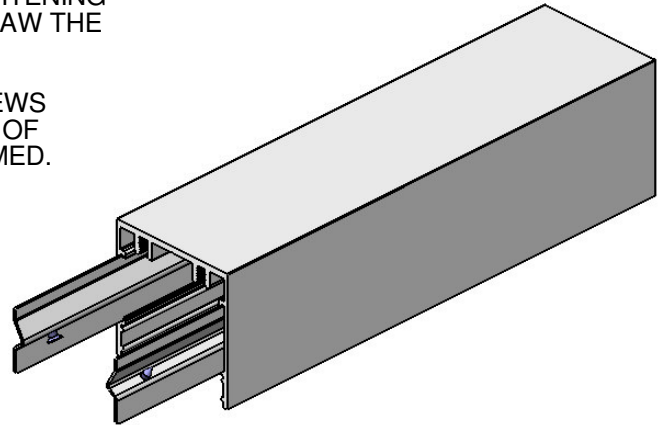

NOTE: IF SUSPENDING MICRO BLADE SYSTEM ENSURE THERE IS A SUSPENSION CLOSE BY TO SUPPORT THE JOIN.

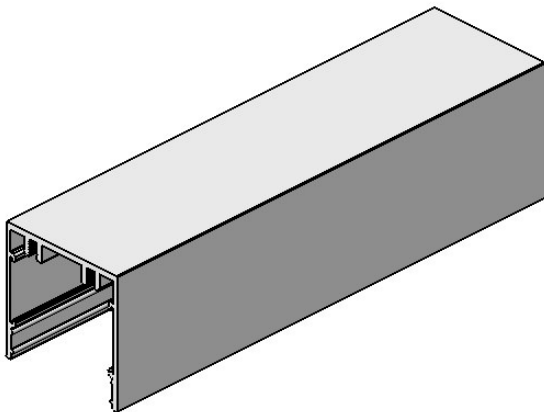

MICRO BLADE STRAIGHT JOINER PLATE SIDES INTO CHANNELS IN EXTRUSION. REDUCES LIGHT SPILL AT JOIN AND HOLDS EXTRUSIONS TOGETHER

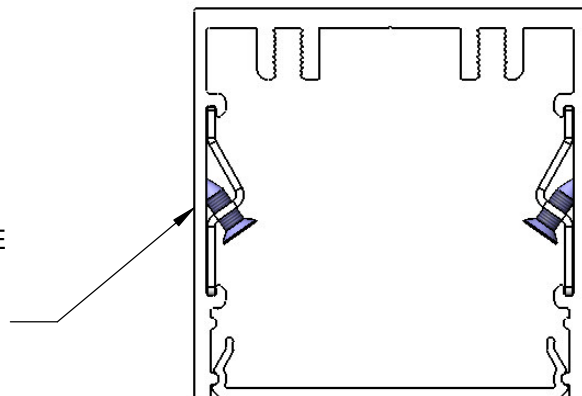

90° Bend Installation Instruction

90° BEND BUILT IN FACTORY.
FIX TO OTHER MICRO BLADE
BUILDING BLOCKS/EXTRUSIONS
AS PER STRAIGHT JOINER.

