

## Straight Joiner Installation Instruction

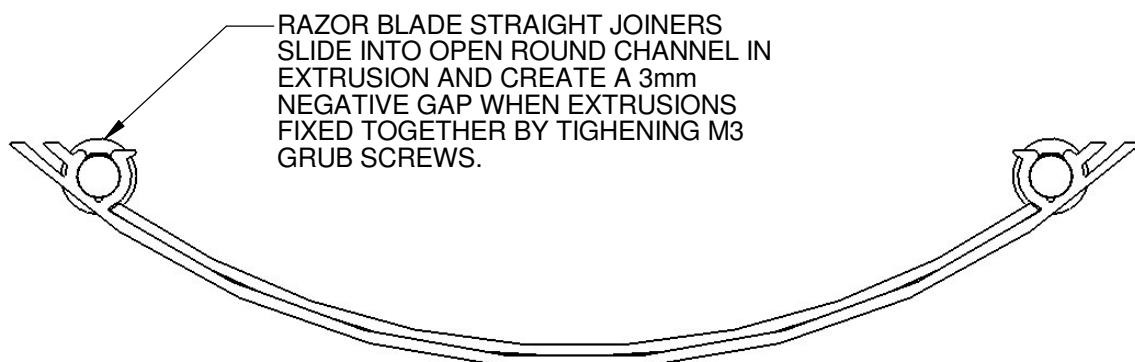

## 90° Bend Installation Instruction

90° BEND BUILT IN FACTORY.  
FIX TO OTHER RAZOR BLADE  
BUILDING BLOCKS/EXTRUSIONS  
AS PER STRAIGHT JOINER.

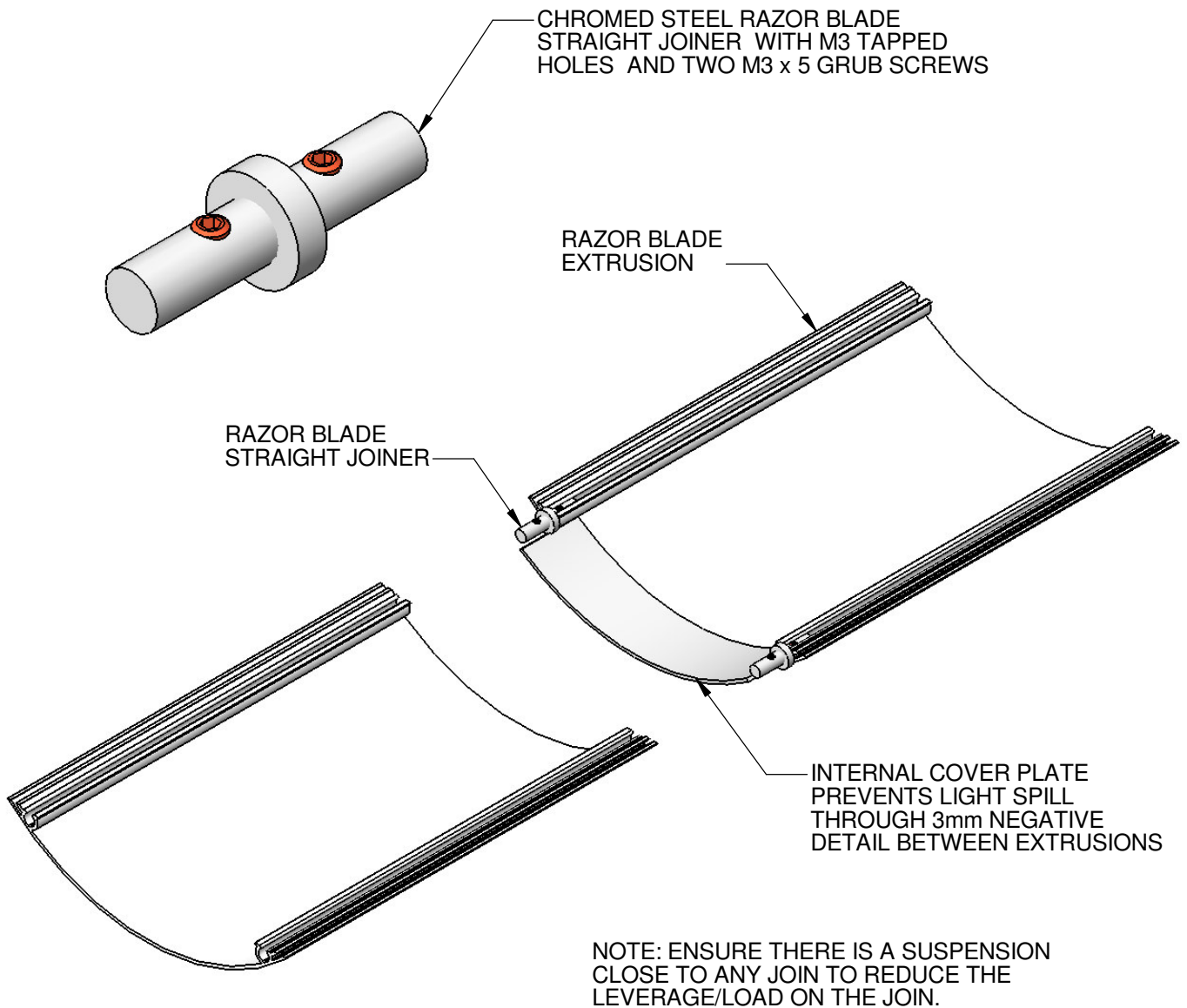
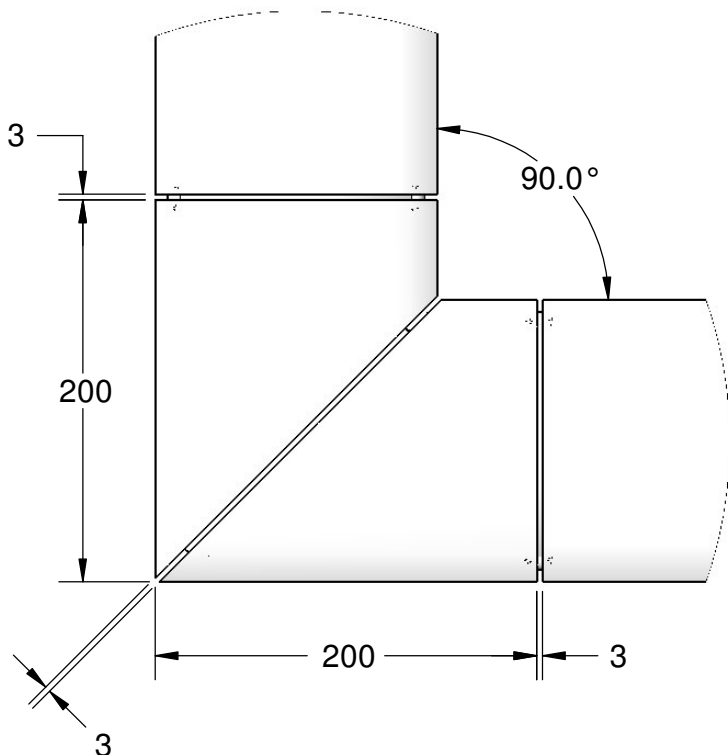
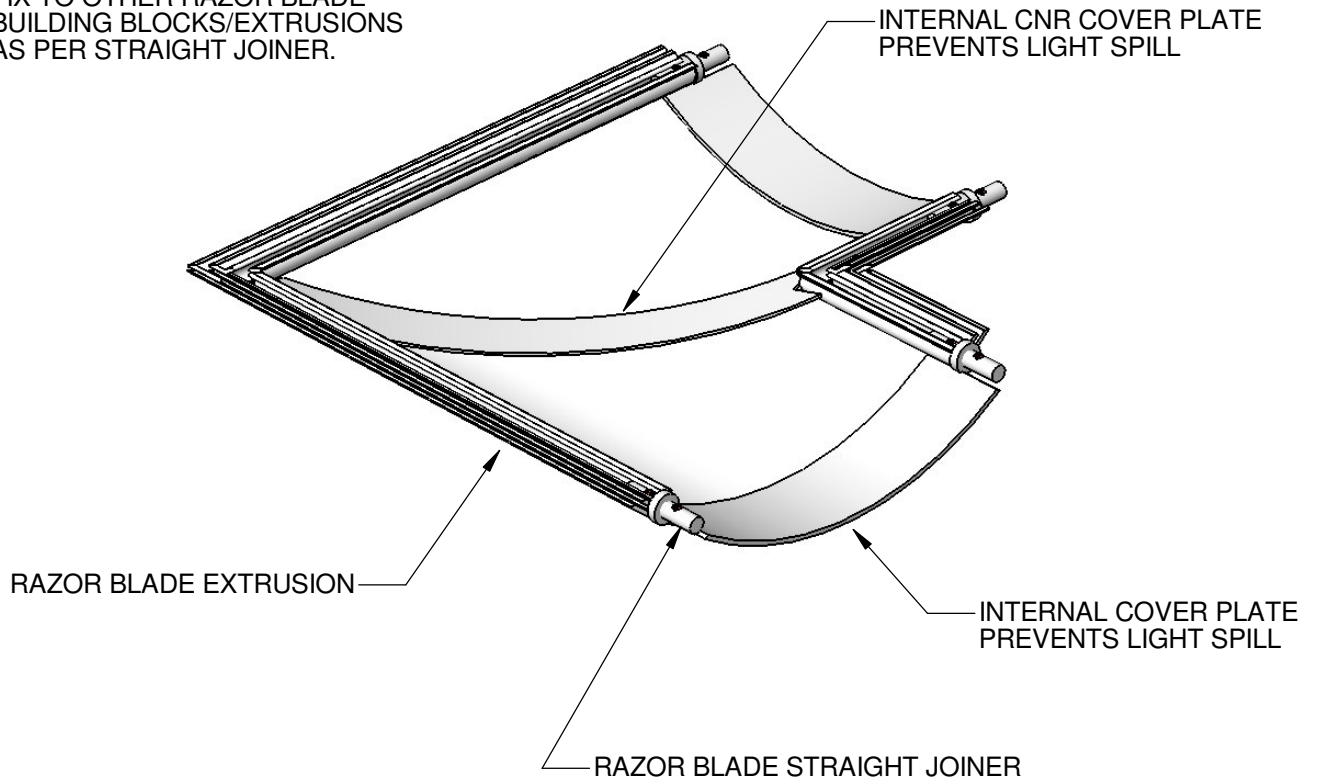

REFER TO RAZOR BLADE  
STRAIGHT JOINER INSTALLATION  
INSTRUCTION FOR FURTHER  
DETAILS.