

## Straight Joiner Installation Instruction

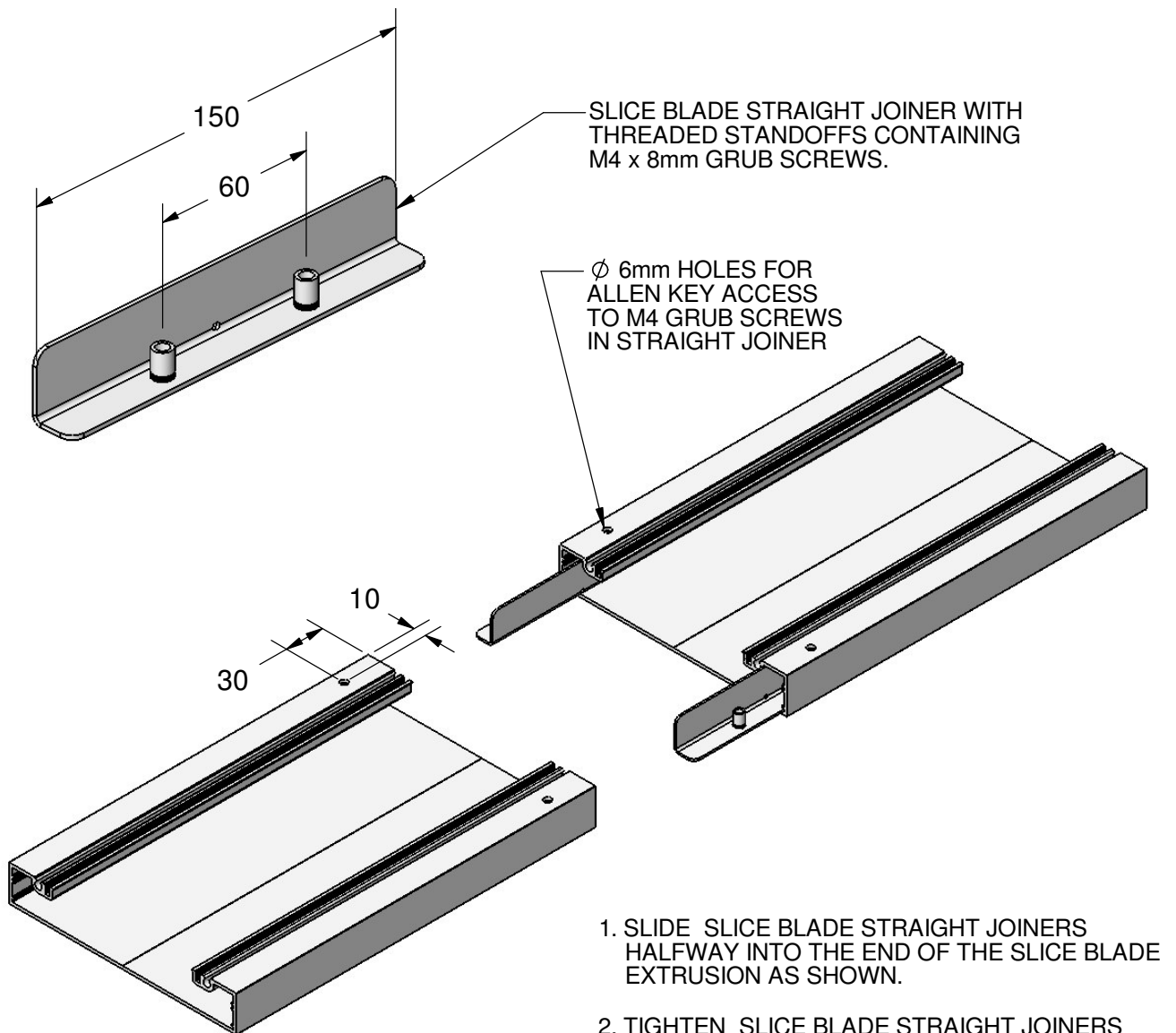

1. SLIDE SLICE BLADE STRAIGHT JOINERS HALFWAY INTO THE END OF THE SLICE BLADE EXTRUSION AS SHOWN.
2. TIGHTEN SLICE BLADE STRAIGHT JOINERS WITH ALLEN KEY THROUGH FACTORY PRE-DRILLED HOLES IN TOP OF SLICE BLADE EXTRUSION. TAKE CARE NOT TO OVER TIGHTEN GRUB SCREWS AND DEFORM EXTRUSION.
3. SLIDE SECOND LENGTH OF SLICE BLADE EXTRUSION ONTO STRAIGHT JOINERS AND HOLD TOGETHER FIRMLY WHILE TIGHTENING GRUB SCREWS IN SECOND EXTRUSION.

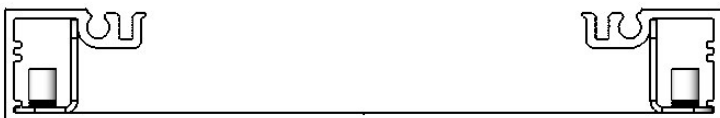

## 90° Bend Installation Instruction

FACTORY ASSEMBLED 90° BEND SUPPLIED WITH STRAIGHT JOINERS FOR FIXING TO SLICE BLADE EXTRUSION LENGTHS.

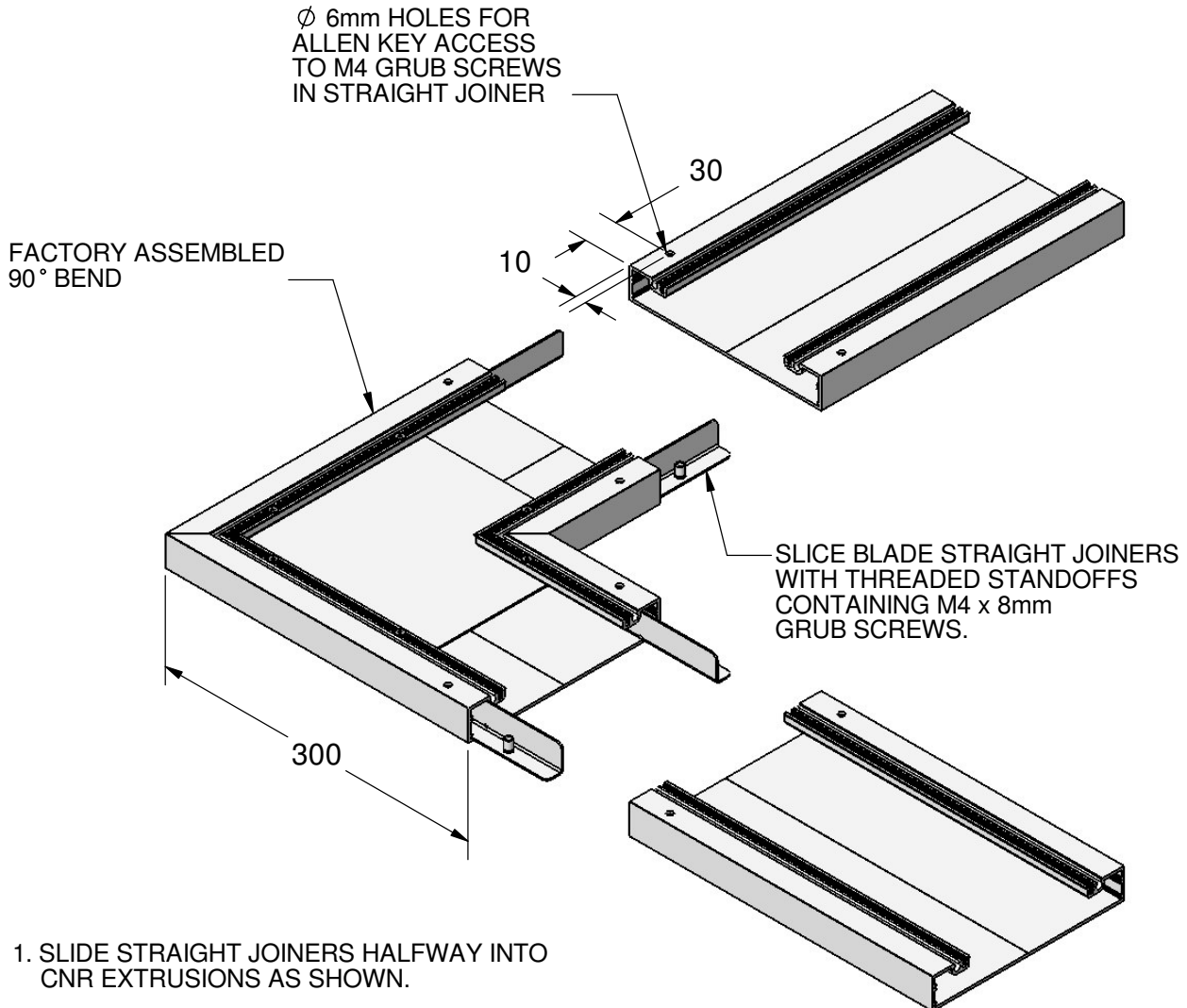

1. SLIDE STRAIGHT JOINERS HALFWAY INTO CNR EXTRUSIONS AS SHOWN.
2. TIGHTEN SLICE BLADE STRAIGHT JOINERS WITH ALLEN KEY THROUGH FACTORY PRE-DRILLED HOLES IN TOP OF SLICE BLADE EXTRUSION. TAKE CARE NOT TO OVERTIGHTEN GRUB SCREWS AND DEFORM EXTRUSION.
3. SLIDE LENGTHS OF SLICE BLADE EXTRUSION ONTO STRAIGHT JOINERS AND HOLD TOGETHER FIRMLY WHILE TIGHTENING GRUB SCREWS. AGAIN TAKE CARE NOT TO OVERTIGHTEN GRUB SCREWS.

