

Straight Joiner Installation Instruction

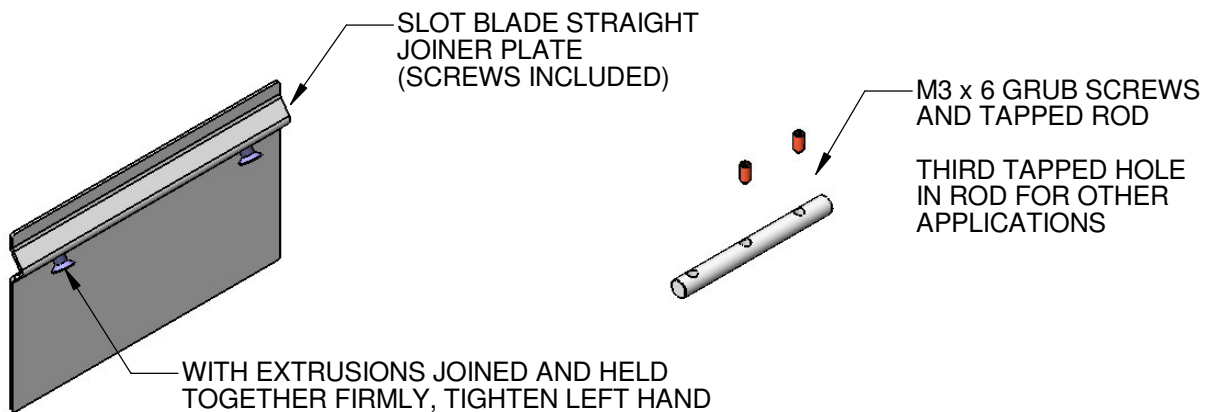

WITH EXTRUSIONS JOINED AND HELD TOGETHER FIRMLY, TIGHTEN LEFT HAND SCREW FIRST. THE TURNING/TIGHTENING OF THE SECOND SCREW WILL DRAW THE EXTRUSIONS TOGETHER MORE.

DO NOT OVERTIGHTEN THE SCREWS OR ELSE THE OUTSIDE SURFACE OF THE EXTRUSION WILL BE DEFORMED.

NOTE: IF SUSPENDING SLOT BLADE SYSTEM ENSURE THERE IS A SUSPENSION CLOSE BY TO SUPPORT THE JOIN.

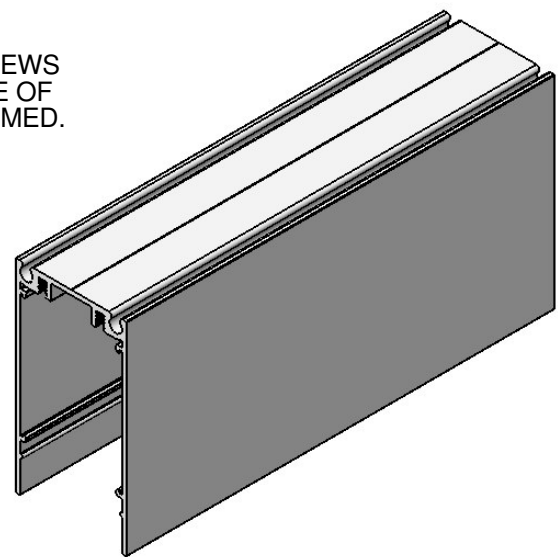
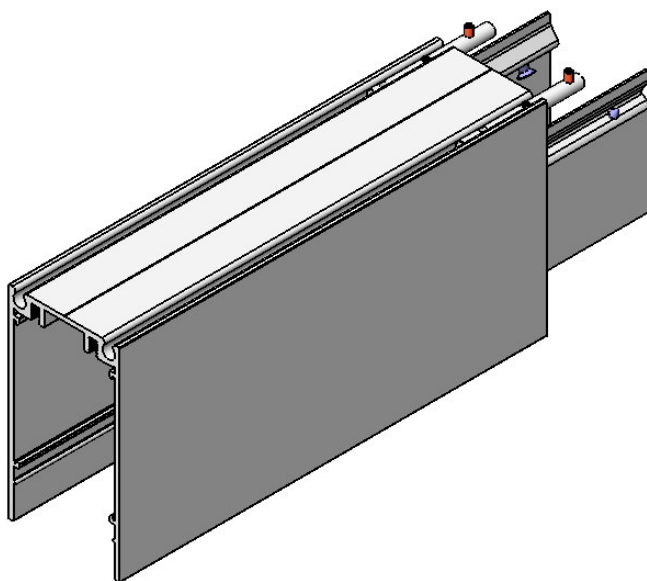

M3 x 6 GRUB SCREWS AND TAPPED ROD JOIN LENGTHS OF EXTRUSION

SLOT BLADE STRAIGHT JOINER PLATE SIDES INTO CHANNELS IN EXTRUSION. PREVENTS LIGHT SPILL AT JOIN AND ASSISTS TO HOLD EXTRUSIONS TOGETHER

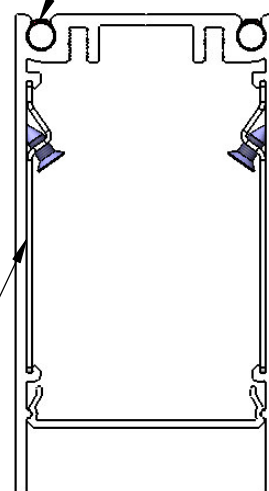

90° Bend Installation Instruction

90° BEND BUILT IN FACTORY.
FIX TO OTHER SLOT BLADE
BUILDING BLOCKS/EXTRUSIONS
AS PER STRAIGHT JOINER.

